



PNEUDRI MiDAS

A totally clean and dry compressed air system (CDA)



domnick hunter

www.domnickhunter.com

PNEUDRI MiDAS - Mini Dry Air System

The Problem

Compressed air is an essential power source that is widely used throughout industry. This safe, powerful and reliable utility can be the most important part of your production process.

However, your compressed air will contain water, dirt, wear particles and even degraded lubricating oil which all mix together to form an unwanted condensate. This condensate often acidic, rapidly wears tools and pneumatic machinery, blocks valves and orifices causing high maintenance and costly air leaks. It also corrodes piping systems and can bring your production process to an extremely expensive standstill!

The use of high efficiency compressed air filters fitted with condensate drains will remove the oil, water and dirt particles to eliminate the abrasive sludge in the compressed air system.

In many cases this action alone is not enough, as modern production systems and processes demand an even higher level of air quality. Where required, "point of use" desiccant air dryers can provide the correct air quality, without the need for drying the complete compressed air installation, which can be both costly and totally unnecessary.



The Efficient Solution

The domnick hunter PNEUDRI MiDAS range of desiccant air dryers, offers the user uncompromised performance from a dedicated "point of use" Clean Dry Air system. It is easy to install and will transform an ordinary process into a highly reliable and efficient production operation.

PNEUDRI MiDAS has been designed with "quick change" filter, dryer combi-cartridges and in-line air connections to facilitate easy maintenance.

PNEUDRI MiDAS totally cleans and dries compressed air down to -40°F (-40°C) pressure dewpoint, meeting the requirements of ISO 8573.1 Class 1.2.1 as standard.

For critical applications, a pressure dewpoint of -100°F (-70°C) ISO 8573.1 Class 1.1.1 is achievable.

The principles of PNEUDRI MiDAS are based upon well proven concepts which embody true innovation and excellent value for money with technically superior yet simple design, while leading the way in compressed air drying.





Prevents unnecessary downtime.
Increases product output by reducing plant downtime.

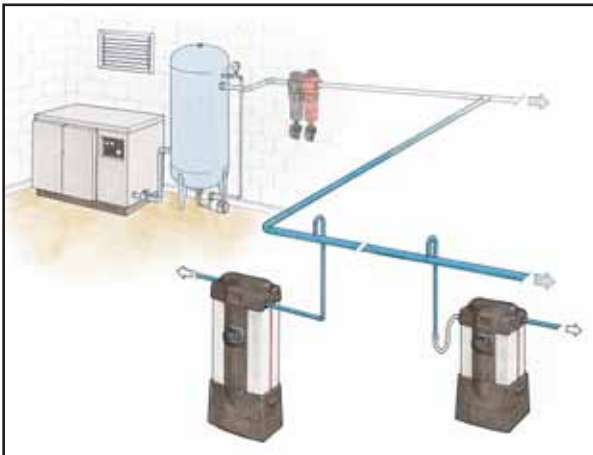

Easy desiccant cartridge replacement

The Benefits are obvious

- **Point Of Use Application.**
Bringing Clean Dry Air just where you need it.
- **Approved to International Standards**
Designed in accordance with ASME VIII Div.1, approved to CSA/UL/CRN and fully CE Marked (PED, EMC, LVD) as standard.
- **Simple to install**
Flexible installation utilizing the multiple in-line inlet & outlet connection ports.
- **Compact and lightweight.**
Can be Floor, Bench or Wall/Canopy mounted.
- **Very Quiet Operation.**
Noise level less than 70dB(A).
- **Can be installed almost anywhere.**
NEMA 4 / IP66 protection as standard.
- **Audible alarm.**
Indicating Service interval for optimal performance.
- **Simple & easy to maintain.**
A 100% service can be achieved insitu in under 15 minutes due to the quick release top cap arrangement, which does NOT require the inlet / outlet ports to be disconnected as with traditional systems.

The PNEUDRI MiDAS Dry Air System, is the reliable, cost effective and flexible way to provide Clean Dry Air exactly where needed.



Seven models in range

Features PNEUDRI MIDAS DAS 1



ISO7000 inlet & outlet symbols cast into the top cover ensure correct piping installation.



Integral Grade AA high efficiency filter.

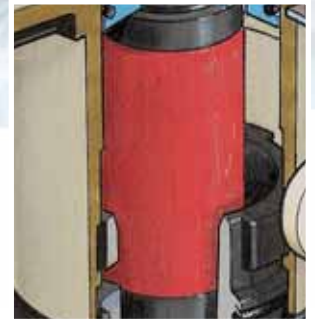

Top End Repressurization – ensuring uninterrupted compressed air at all times.



Electronic display providing high visibility LED indication with an internal audible alarm.



Alarm reset facility to cancel the audible alarm for 24 hours while replacement components are sourced.

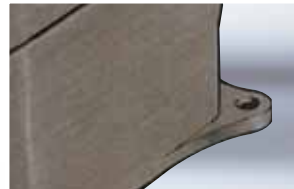

Easy access to electronic control box for mains connection.



Positive removal of prefilter condensate by piping away for remote collection.



Patented high tensile extruded aluminum column with twin drying chambers.



One Combi-Cartridge per column containing DRYFIL® MS desiccant and Grade AR particulate filter.



Corrosion protected by alclom and epoxy painting.

Optional Features

- For totally quiet operation, the regeneration exhaust air can be positively piped away.
- Remote indication provides a warning of the dryers need for servicing. (Audible alarm not included)
- Wall mounting kit for vertically securing the dryer to a wall or canopy.



Tilt mounting kit facilitates easy cartridge replacement

A 45° tilt, wall mounting kit is also available for vertically securing the dryer to a wall, canopy or inside a customers product where access to the top of the dryer is restricted.

- In conditions of limited access, the electronic control box (base) can be detached and relocated remotely from the dryer.



Electronic control box can be remotely located

Product Applications

PNEUDRI MiDAS will benefit users who have a specific need for Clean Dry Air (CDA) directly after a compressor, or for a particular application where the air is critical to the operating process or end product.



PNEUDRI MiDAS installed to supply control air for a CNC machining center

Typical Applications:

- Computer Numerical Control (CNC) Machines
- Co-ordinate Measuring Machines
- Laboratories
- Lasers
- Packaging Machines
- Instrumentation
- Processing equipment
- Conveying Machines

Operation

1 Compressed air enters the integral pre-filter and passes into the left hand chamber (Column A) where the air is dried before passing to the application.

A small amount of dry purge air is used to regenerate the right hand chamber (Column B) which is wet, using the PSA (Pressure Swing Adsorption) method of regeneration, venting the saturated air to atmosphere under pressure. The same regeneration air is also used to "back flush" the integral filter to prolong its working life.

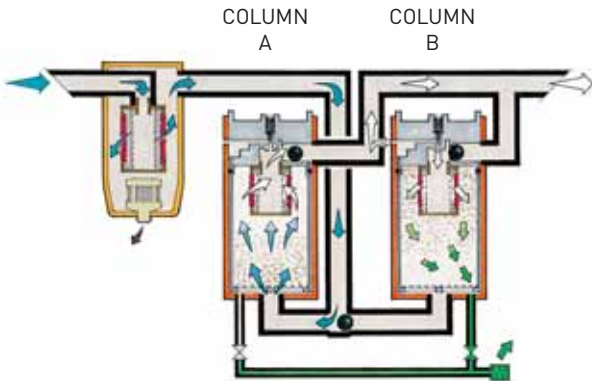

2 Prior to changeover, the right hand chamber (Column B) enters repressurization where the exhaust valve is closed to allow pressure to increase. This process ensures a smooth uninterrupted changeover, preventing the loss of any system pressure, before the process repeats itself.

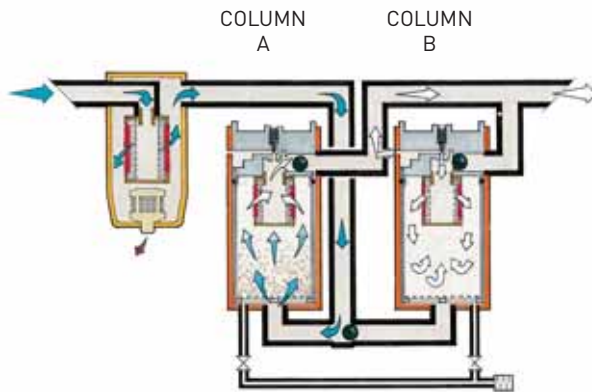

Service Indication Sequence & Alarm

During operation, PNEUDRI MIDAS Power On (yellow) LED and Check (Green) LED indicators will illuminate, remaining in this configuration for 11500 hours. At this time, the Warning (Yellow) LED will illuminate and cancel the Check (Green) LED. This signals the user to order service replacement components at the optimum time.

500 hours later (a total of 12000 hours from initial start up) the Service (Red) LED will illuminate and cancel the Warning (Yellow) LED, the Audible Alarm housed inside the display will sound intermittently (every 6 seconds) drawing attention to the need for a service.



Selection Criteria

To correctly select the dryer best suited for your application, the following details are required to ensure optimum performance and trouble free operation.

- Maximum Inlet Flow
- Minimum Inlet Pressure
- Maximum Inlet Temperature.

Once these operating parameters have been established, you can select the most economical PNEUDRI MiDAS for your application.



Sizing Chart (Correction)

Minimum Inlet Pressure		Maximum Inlet Temperature °F (°C)			
psi g	bar g	95 (35)	104 (40)	113 (45)	122 (50)
58	4	0.63	0.61	0.55	0.46
73	5	0.75	0.73	0.66	0.55
87	6	0.88	0.85	0.77	0.64
100	7	1.00	0.97	0.88	0.73
116	8	0.97	0.94	0.85	0.71
135	9	1.08	1.05	0.95	0.79
145	10	1.18	1.14	1.04	0.86
160	11	1.29	1.25	1.14	0.94
175	12	1.40	1.36	1.23	1.02

Model Selector

Model	Flow Rates	
	cfm	m ³ /hr
DAS1	3	5.1
DAS2	5	8.5
DAS3	8	13.6
DAS4	10	17.0
DAS5	13	22.1
DAS6	15	25.5
DAS7	20	34.0

Referenced to 68°F (20°C) and 14.5 psi a (1 bar a)

Example

Selecting a dryer for a compressor producing, at full load 8 cfm (13.6 m³/hr) at 87 psi g (6 bar g) with 95°F (35°C) air inlet temperature and a pressure dewpoint requirement of -40°F (-40°C).

Step 1

From the sizing chart select the required pressure @ 87 psi g (6 bar g) and read across to the required inlet temperature @ 95°F (35°C). The Correction Factor is 0.88

Step 2

To adjust the flow for your application, divide the required flow by the 0.88. Correction Factor

Example:

$$\text{Sizing Capacity} = \frac{\text{Actual Flow}}{\text{Correction Factor}} = \frac{8 \text{ cfm (13.6 m}^3\text{/hr)}}{0.88} = 9 \text{ cfm (15.5 m}^3\text{/hr)}$$

Step 3

From the Model Selector, select the dryer which has a rated flow capacity of 9 cfm (15.5 m³/hr) or higher.

Selected model for this example is a PNEUDRI MiDAS DAS 4.

Technical Specifications

Flow Range:	3 cfm (5.1 m ³ /hr) to 20 cfm (34.0 m ³ /hr) at 100 psi g (7 bar g)	Standard Electrical Supply: *	230/1ph/50Hz (Tolerance +/- 10%) 115/1ph/60Hz (Tolerance +/- 10%)
Minimum Operating Pressure:	58 psi g (4 bar g)	Controls:	Electronic Control Timer
Maximum Operating Pressure:	175 psi g (12 bar g)	Inlet Connections:	3/8" NPT
Minimum Operating Temperature:	35°F (1.5°C)	Outlet Connections:	3/8" NPT
Maximum Inlet Temperature:	122°F (50°C)		
Noise Levels (Average):	≤70dB(A)		
Pressure Dewpoint (Standard):	-40°F pdp [-40°C pdp] (ISO8573.1 Class 1.2.1) (optional): -100°F pdp [-70°C pdp] (ISO8573.1 Class 1.1.1)		

* Other voltages available.

Weights and Dimensions

Model	Dimensions ins (mm) A	Weight lbs (kg)
DAS1	16.6 (422)	24.2 (11)
DAS2	19.7 (500)	28.7 (13)
DAS3	24.2 (616)	35.3 (16)
DAS4	27.2 (692)	39.7 (18)
DAS5	33.3 (847)	44.1 (20)
DAS6	35.7 (906)	50.7 (23)
DAS7	43.2 (1098)	61.7 (28)

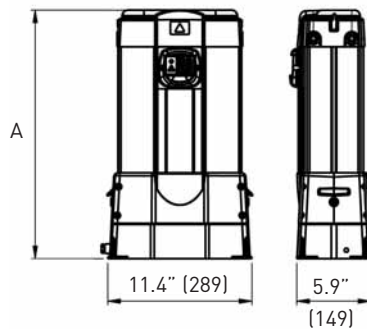

Maintenance Kits

Fixing Kits

Description	Kit
Fixed Wall Mounting Bracket	DASMB1
45° Tilt Wall Mounting Bracket	DASMB2

Maintenance Kits

Model	Maintenance Kit
DAS 1	DASMK1
DAS 2	DASMK2
DAS 3	DASMK3
DAS 4	DASMK4
DAS 5	DASMK5
DAS 6	DASMK6
DAS 7	DASMK7

www.domnickhunter.com



dh and domnick hunter are registered trademarks of Parker-Hannifin Corporation.

domnick hunter has a continuous policy of product development and although the Company reserves the right to change specifications, it attempts to keep customers informed of any alterations. This publication is for general information only and customers are requested to contact your domnick hunter sales representative for detailed information and advice on a products suitability for specific applications. All products are sold subject to the Company's standard conditions of sale.

© 2007 Parker-Hannifin Corporation
Publication Reference: 743 11/04 Rev.006 USA 05/08
Stock No. 17 400 4743



domnick hunter

Parker Hannifin
domnick hunter division
North Carolina, USA
Tel: (704) 921-9303
Toll Free: 1-800-345-8462
Telefax: (704) 921-1960

domnick hunter Canada
Ontario, Canada
Tel: (905) 820-7146
Toll Free: 1-888-342-2623
Telefax: (905) 820-5463

